

标记 MARK	更改内容 MODIFICATION	日期 DATE	修改 DRAW	核准 APPROVE

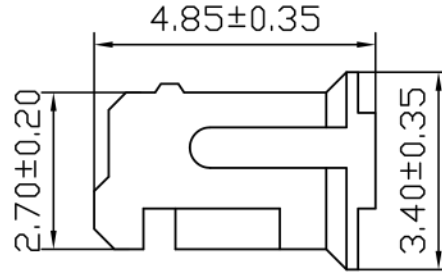
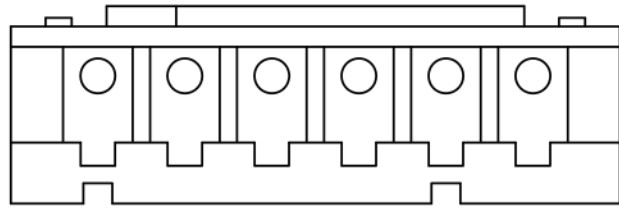

技术要求Specification:

- 1、材质Material: PA66 UL94V-0;
- 2、塑件表面平整光洁, 无明显的毛刺、气泡、变形、浇口拉伤、缺料等不良现象。

Plastic surface smooth and clean, no obvious burrs, bubbles, distortion, gate strain, lack of material and other undesirable phenomena.

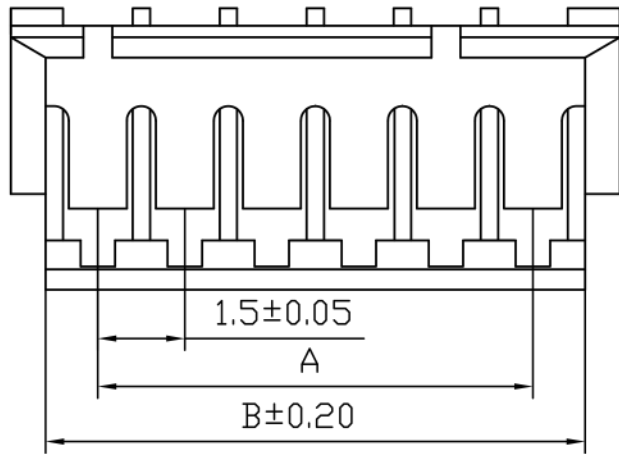

线数 poles	型号 Type	尺寸Dimensions mm	
		A	B
2	ZH-2Y	1.5	3.3
3	ZH-3Y	3	4.8
4	ZH-4Y	4.5	6.3
5	ZH-5Y	6	7.8
6	ZH-6Y	7.5	9.3
7	ZH-7Y	9	10.8
8	ZH-8Y	10.5	12.3
9	ZH-9Y	12	13.8
10	ZH-10Y	13.5	15.3
11	ZH-11Y	15	16.8
12	ZH-12Y	16.5	18.3
20	ZH-20Y	28.5	30.3

TOLERANCE UNLESS OTHERWISE SPECIFIED		*: Inspection Item		www.canner.co.in			
.X±0.30	X.° ±1°	(NO.)	:Cp/Cpk and SPC Control Item				
.XX±0.20	.X° ±	材料 MATERIAL	PA66	名称 TITLE	ZH-Y HOUSING		
.XXX±0.10	.XX° ±	料厚 THICK	/	编号 DWG NO.	SH15000-NY	单位 UNIT	mm
		料宽 WIDE	/	比例 SCALE	1:1	版本 REV.	A
制图 DRAWIN	谭猛	日期 DATE	2014. 5. 11	角法 PROJ.		规格书	
审核 CHECKED	林金喜						
批准 APPROVE	江树钦						

标记 MARK	更改内容 MODIFICATION	日期 DATE	修改 DRAW	核准 APPROVE

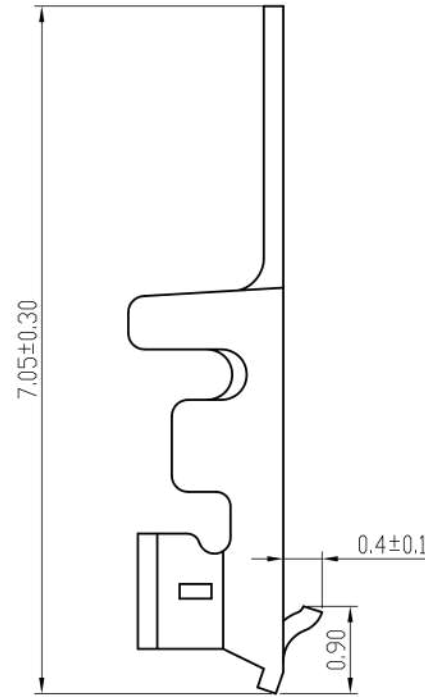
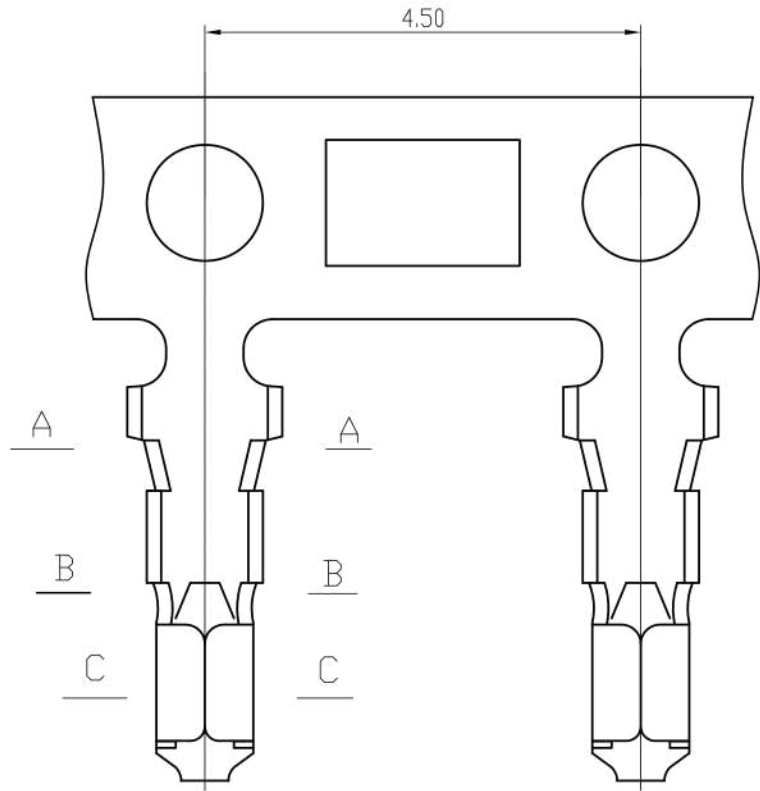

技术要求Specification:

1、材质：磷青铜，表面镀锡，

Material:Phos.Bronze Tin-Plated

2、零件外观不得有有害毛刺、尖角、锐边和机械损伤；表面镀层应均匀、光亮、无雾斑、剥层等缺陷；

Parts may not have the appearance of harmful burrs,sharp corners,sharp edges and mechanical damage,surface coating should be uniform, bright,no fog spots,delamination and other defects.

3、适用线号：AWG#32-#26；

Wirerange: AWG#32-#26；

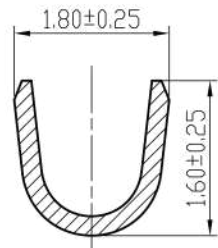

A-A

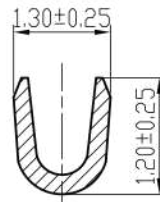

B-B

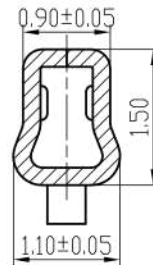

C-C

TOLERANCE UNLESS OTHERWISE SPECIFIED		*: Inspection Item		Canner® www.canner.co.in					
.X±0.30	X.° ±1°	NO.	:Cp/Cpk and SPC Control Item	材料	磷青铜	名称	ZH-T TERMINAL		
.XX±0.20	.X° ±			料厚	0.20 mm	编号	SH1500-T	单位	mm
.XXX±0.10	.XX° ±			料宽		比例	1:1	版本	A1
制图	赵旭强	日期	2020.05.12	角法		规格书			
审核	江树钦	批准	谭猛						
批准	谭猛								