

标记 MARK	更改内容 MODIFICATION	日期 DATE	修改 DRAW	核准 APPROVE

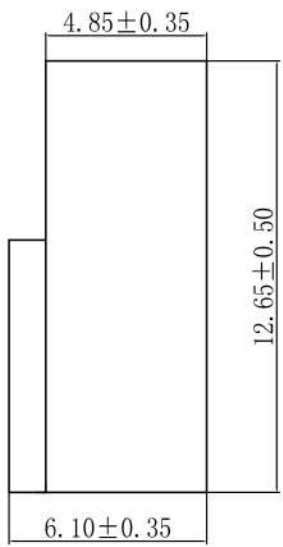
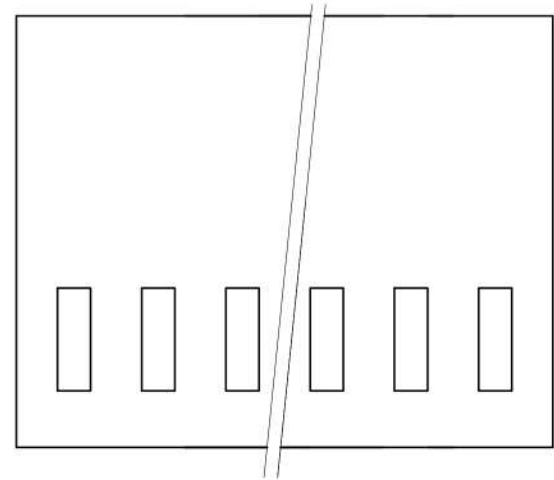
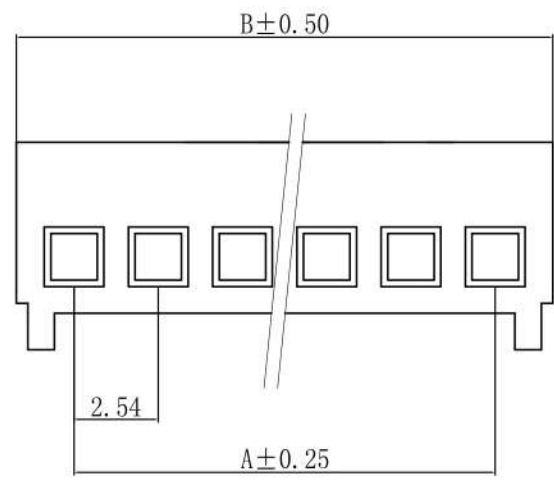

技术要求Specification:

- 1、材质Material: PA66 UL94V-2(0);
- 2、额定电流 Current rating:3.0A AC,DC
- 3、额定电压 Voltage rating: 250V AC,DC
- 4、温度范围 Temperature range:-25℃to+85℃
- 5、接触电阻 Contact resistance:≤20mΩ
- 6、绝缘电阻 Insulation resistance:≥1000MΩ
- 7、耐压 Withstand voltage:1000V AC/minute
- 8、塑件表面平整光洁, 无明显的毛刺、气泡、变形、浇口拉伤、缺料等不良现象。  
Plastic surface smooth and clean, no obvious glitches, bubbles, distortion, gate strain, lack of material and other undesirable phenomena.

线数	型号	尺寸	
		A	B
2	SH25402-2Y	2.54	5.72
3	SH25402-3Y	5.08	8.26
4	SH25402-4Y	7.62	10.80
5	SH25402-5Y	10.16	13.34
6	SH25402-6Y	12.70	15.88
7	SH25402-7Y	15.24	18.42
8	SH25402-8Y	17.78	20.96
9	SH25402-9Y	20.32	23.50
10	SH25402-10Y	22.86	26.04
11	SH25402-11Y	25.40	28.58
12	SH25402-12Y	27.94	31.12
13	SH25402-13Y	30.48	33.66
14	SH25402-14Y	33.02	36.20
15	SH25402-15Y	35.56	38.74
16	SH25402-16Y	38.10	41.28

TOLERANCE UNLESS OTHERWISE SPECIFIED		*: Inspection Item		 <a href="http://www.canner.co.in">www.canner.co.in</a>			
.X±0.30	X." ±1"	(NO.)	:Cp/Cpk and SPC Control Item				
.XX±0.20	.X° ±	材料	PA66	名称	2510 HOUSING		
.XXX±0.10	.XX° ±	MATERIAL		TITLE			
制图	丁浩然	料厚	/	编号	SH25402-NY	单位	mm
DRAWN		THICK			DWG NO.		UNIT
审核	林云昆	料宽	/	比例	1:1	版本	A
CHECKED		WIDE			SCALE		REV.
批准	谭猛	日期	2024.08.08	角法		规格书	
APPROVE		DATE		PROJ.			

标记 MARK	更改内容 MODIFICATION	日期 DATE	修改 DRAW	核准 APPROVE

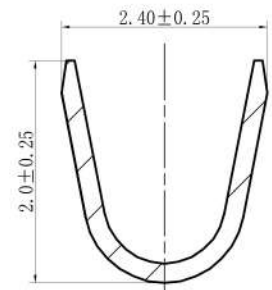
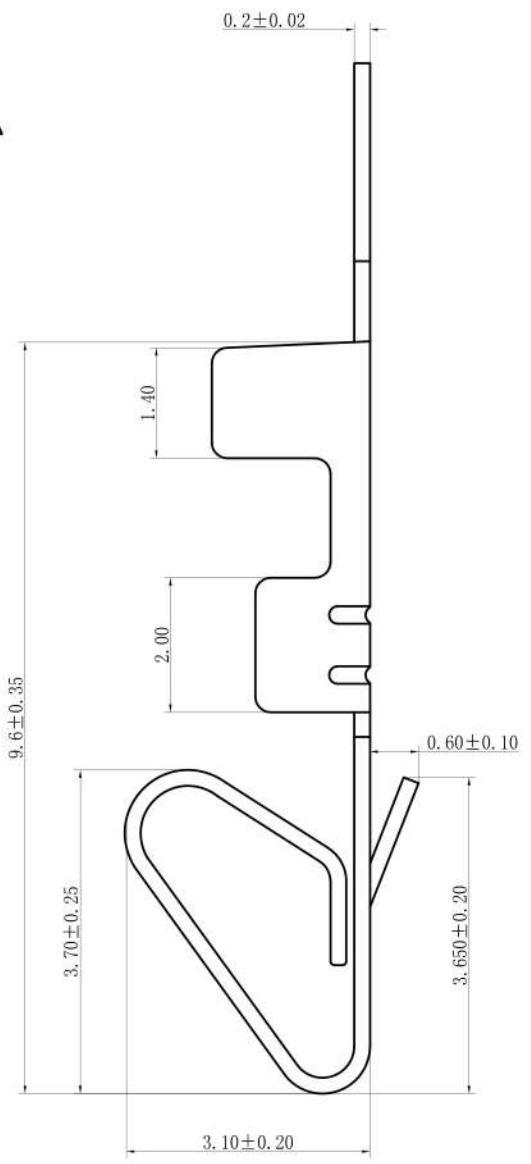
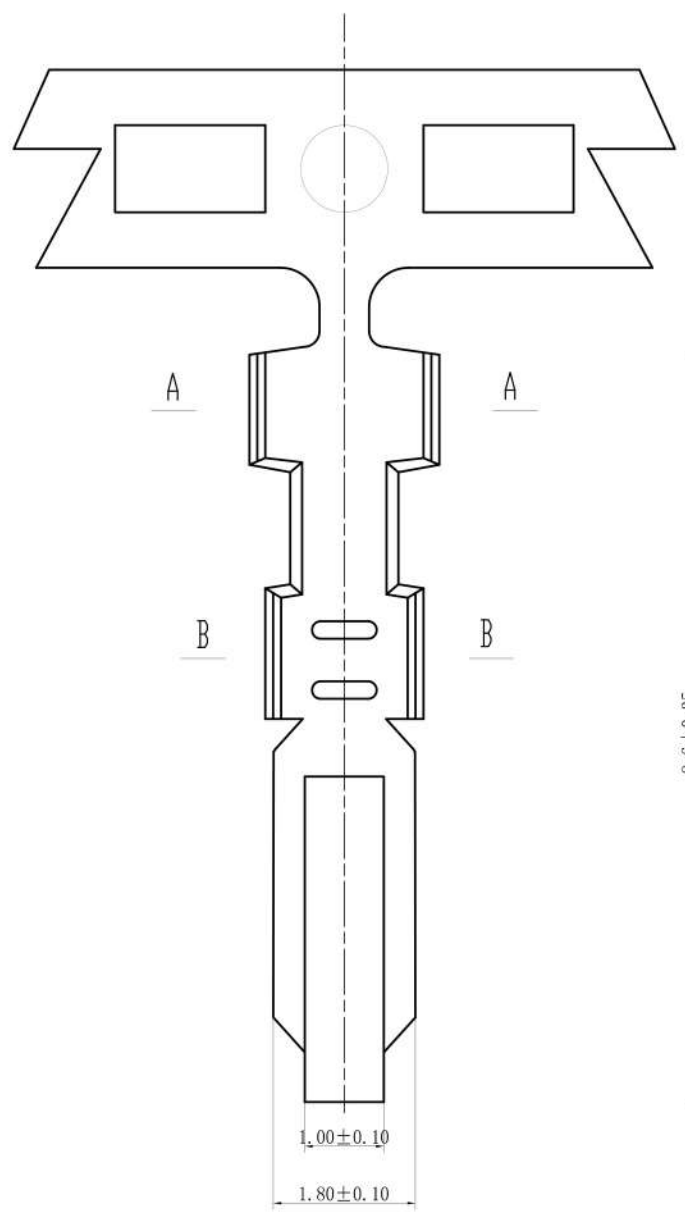

SECTION A-A

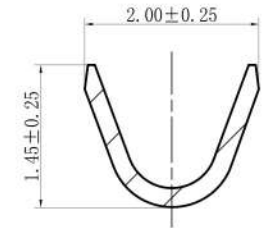

SECTION B-B

技术要求Specification:

- 1、材质：磷青铜，表面镀锡，  
Material: Phos. Bronze Tin-Plated
- 2、零件外观不得有有害毛刺、尖角、锐边和机械损伤；表面镀层应均匀、光亮、无雾斑、剥层等缺陷；  
Parts may not have the appearance of harmful burrs, sharp corners, sharp edges and mechanical damage, surface coating should be uniform, bright, no fog spots, delamination and other defects.
- 3、适用线号：AWG#28-#22；  
Wirerange: AWG#28-#22；

TOLERANCE UNLESS OTHERWISE SPECIFIED		*: Inspection Item		Canner® www.canner.co.in					
.X±0.30	X." ±1"	NO.	:Cp/Cpk and SPC Control Item	材料	磷青铜	名称	2510 Termianl		
.XX±0.20	.X° ±			料厚	0.20mm	编号	SH25402-T	单位	m m
.XXX±0.10	.XX' ±			料宽		比例	1:1	版本	A1
制图	谭猛	料宽		角法	角法	规格书			
审核	林金喜	日期	2017.09.06	角法					
批准	江树钦	日期	2017.09.06	角法					

标记 MARK	更改内容 MODIFICATION	日期 DATE	修改 DRAW	核准 APPROVE

技术要求Specification:  
 1、材质Material: PA66 UL94V-2(0);  
 2、塑件表面平整光洁, 无明显的毛刺、气泡、变形、浇口拉伤、缺料等不良现象。  
 Plastic surface smooth and clean, no obvious glitches, bubbles, distortion, gate strain, lack of material and other undesirable phenomena.

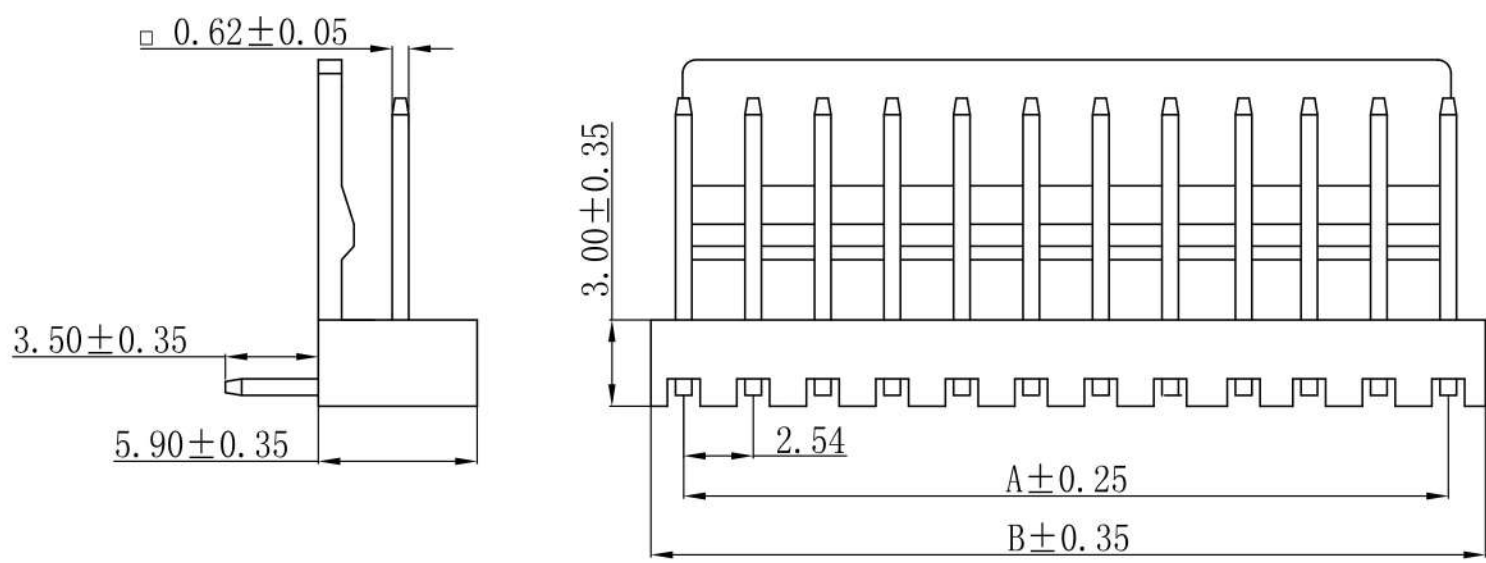

线数	型号	尺寸	
		A	B
2	SH25402-2AWP	2.54	5.08
3	SH25402-3AWP	5.08	7.62
4	SH25402-4AWP	7.62	10.16
5	SH25402-5AWP	10.16	12.70
6	SH25402-6AWP	12.70	15.24
7	SH25402-7AWP	15.24	17.78
8	SH25402-8AWP	17.78	20.32
9	SH25402-9AWP	20.32	22.86
10	SH25402-10AWP	22.86	25.40
11	SH25402-11AWP	25.40	27.94
12	SH25402-12AWP	27.94	30.48
13	SH25402-13AWP	30.48	33.02
14	SH25402-14AWP	33.02	35.56
15	SH25402-15AWP	35.56	38.10
16	SH25402-16AWP	38.10	40.64

TOLERANCE UNLESS OTHERWISE SPECIFIED		*: Inspection Item		 <a href="http://www.canner.co.in">www.canner.co.in</a>		
.X±0.30	X." ±1"	NO.	:Cp/Cpk and SPC Control Item			
.XX±0.20	.X° ±	材料 MATERIAL	PA66	名称 TITLE	2510-NAWP	
.XXX±0.10	.XX° ±	料厚 THICK	/	编号 DWG NO.	SH25402-NAWP	
		料宽 WIDE		比例 SCALE	1:1	单位 UNIT
制图 DRAWN	丁浩然	批准 APPROVE	日期 DATE	2024.08.08	角法 PROJ.	规格书
审核 CHECKED	林云昆				版本 REV.	A

标记 MARK	更改内容 MODIFICATION	日期 DATE	修改 DRAW	核准 APPROVE

技术要求Specification:  
 1、材质Material: PA66 UL94V-2(0);  
 2、塑件表面平整光洁, 无明显的毛刺、气泡、变形、浇口拉伤、缺料等不良现象。  
 Plastic surface smooth and clean, no obvious glitches, bubbles, distortion, gate strain, lack of material and other undesirable phenomena.

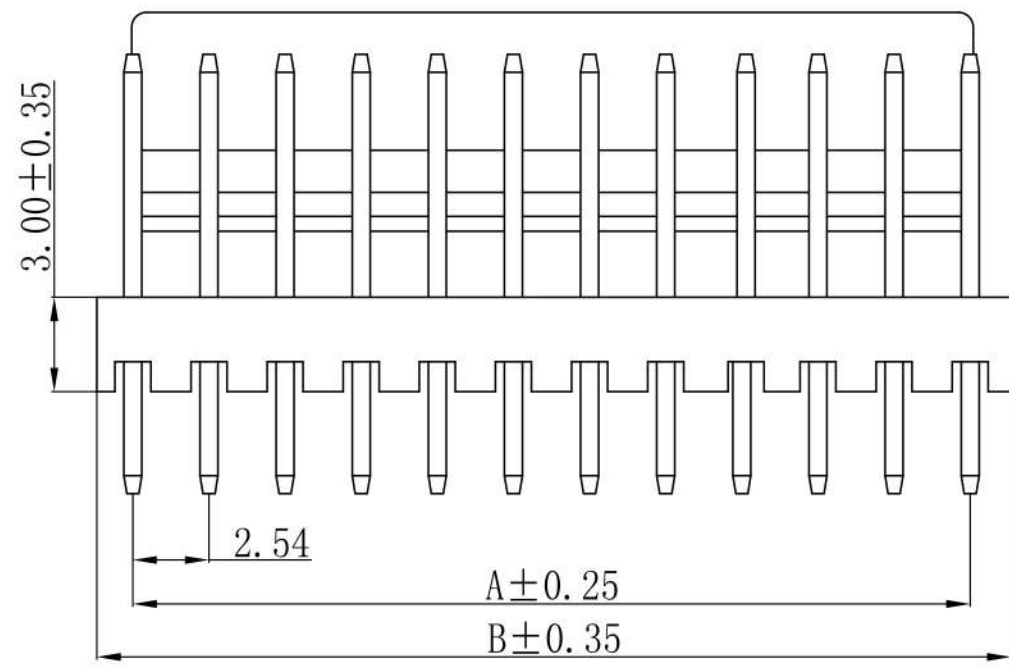
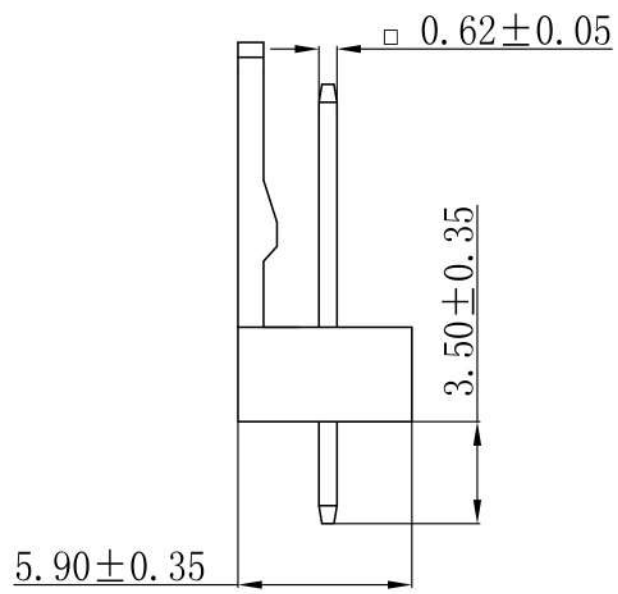

线数	型号	尺寸	
		A	B
2	SH25402-2A	2.54	5.08
3	SH25402-3A	5.08	7.62
4	SH25402-4A	7.62	10.16
5	SH25402-5A	10.16	12.70
6	SH25402-6A	12.70	15.24
7	SH25402-7A	15.24	17.78
8	SH25402-8A	17.78	20.32
9	SH25402-9A	20.32	22.86
10	SH25402-10A	22.86	25.40
11	SH25402-11A	25.40	27.94
12	SH25402-12A	27.94	30.48
13	SH25402-13A	30.48	33.02
14	SH25402-14A	33.02	35.56
15	SH25402-15A	35.56	38.10
16	SH25402-16A	38.10	40.64

TOLERANCE UNLESS OTHERWISE SPECIFIED		*: Inspection Item		www.canner.co.in		
.X ± 0.30	X.° ± 1"	NO.	: Cp/Cpk and SPC Control Item			
.XX ± 0.20	.X° ±	材料	PA66	名称	2510-NA	
.XXX ± 0.10	.XX° ±	料厚		编号	SH25402-NA	
制图	丁浩然	料宽		比例	1:1	单位
审核	林云昆	日期	2024.08.08	版本	A	
批准	谭猛	角法		规格书		