

标记 MARK	更改内容 MODIFICATION	日期 DATE	修改 DRAW	核准 APPROVE

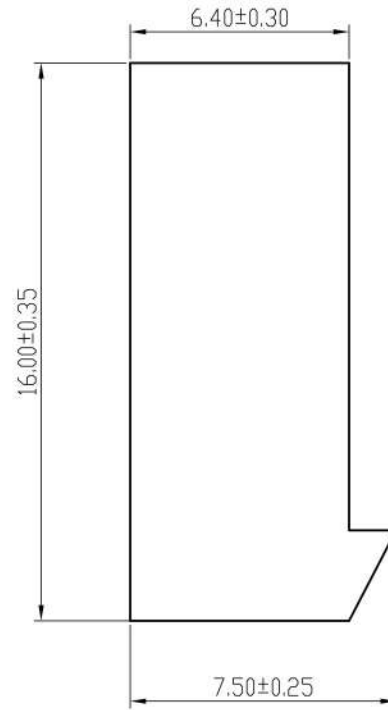
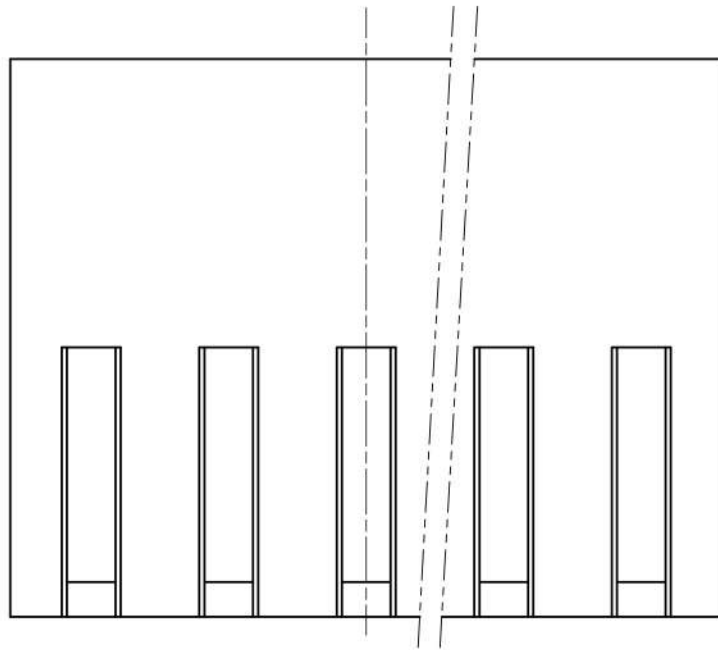

技术要求Specification:

- 1、材质Material: PA66 UL94V-2;
- 2、额定电流 Current rating:5.0A AC,DC
- 3、额定电压 Voltage rating: 250V AC,DC
- 4、温度范围 Temperature range:-25℃to+85℃
- 5、接触电阻 Contact resistance:≤10mΩ
- 6、绝缘电阻 Insulation resistance:≥1000MΩ
- 7、耐压 Withstand voltage:1500V AC/minute
- 8、塑件表面平整光洁, 无明显的毛刺、气泡、变形、浇口拉伤、缺料等不良现象。

Plastic surface smooth and clean, no obvious burrs, bubbles, distortion, gate strain, lack of material and other undesirable phenomena.

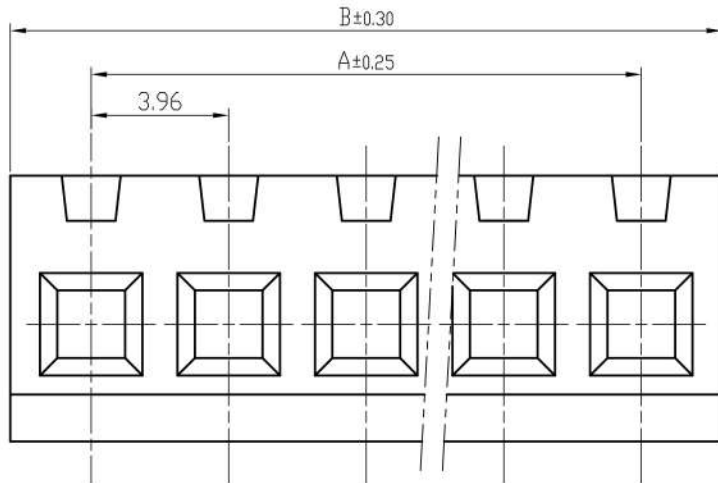

线数	型号	尺寸	
		A	B
2	SH39601-2Y	3.96	8.52
3	SH39601-3Y	7.92	12.48
4	SH39601-4Y	11.88	16.44
5	SH39601-5Y	15.84	20.40
6	SH39601-6Y	19.80	24.36
7	SH39601-7Y	23.76	28.32
8	SH39601-8Y	27.72	32.28
9	SH39601-9Y	31.68	36.24
10	SH39601-10Y	35.64	40.20
11	SH39601-11Y	39.60	44.16
12	SH39601-12Y	43.56	48.12
13	SH39601-13Y	47.52	52.08
14	SH39601-14Y	51.48	56.04
15	SH39601-15Y	55.44	60.00
16	SH39601-16Y	59.40	63.96

TOLERANCE UNLESS OTHERWISE SPECIFIED		*: Inspection Item		Canner® www.canner.co.in		
.X±0.30	X.° ±1°	(NO.)	:Cp/Cpk and SPC Control Item	名称 TITLE	TJC6-NY	
.XX±0.20	.X° ±	材料 MATERIAL	PA66	编号 DWG NO.	SH39601-NY	单位 UNIT
.XXX±0.10	.XX° ±	料厚 THICK		比例 SCALE	1:1	版本 REV.
制图 DRAWIN	丁浩然	料宽 WIDE		角法 PROJ.	第一角	规格书
审核 CHECKED	林云昆	日期 DATE	2024.08.07			
批准 APPROVE	谭猛					

标记 MARK	更改内容 MODIFICATION	日期 DATE	修改 DRAW	核准 APPROVE

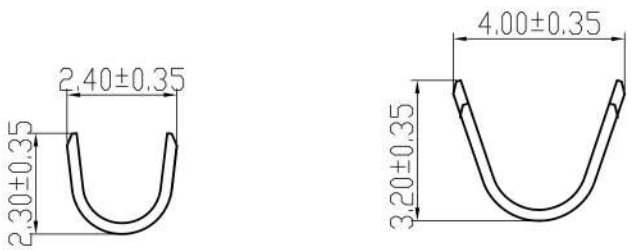
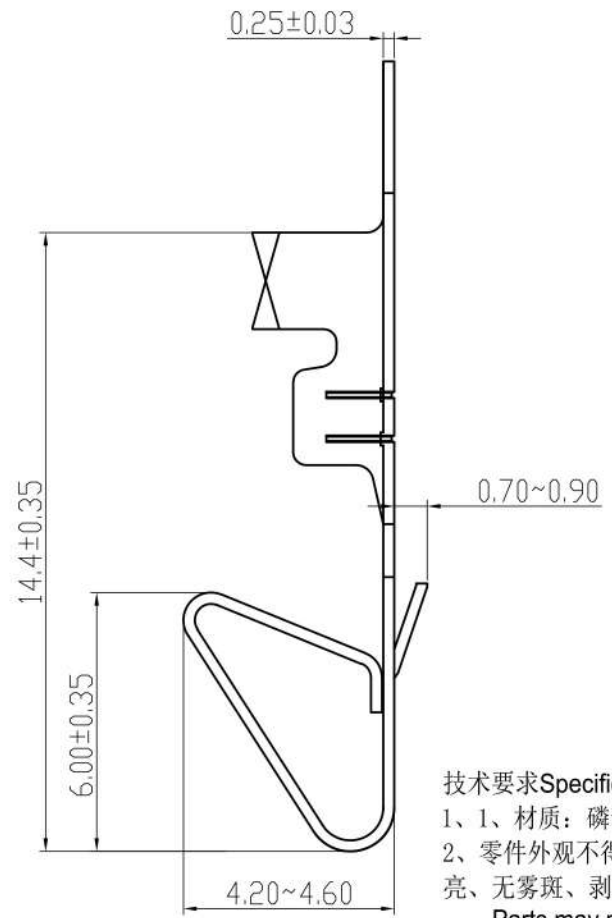
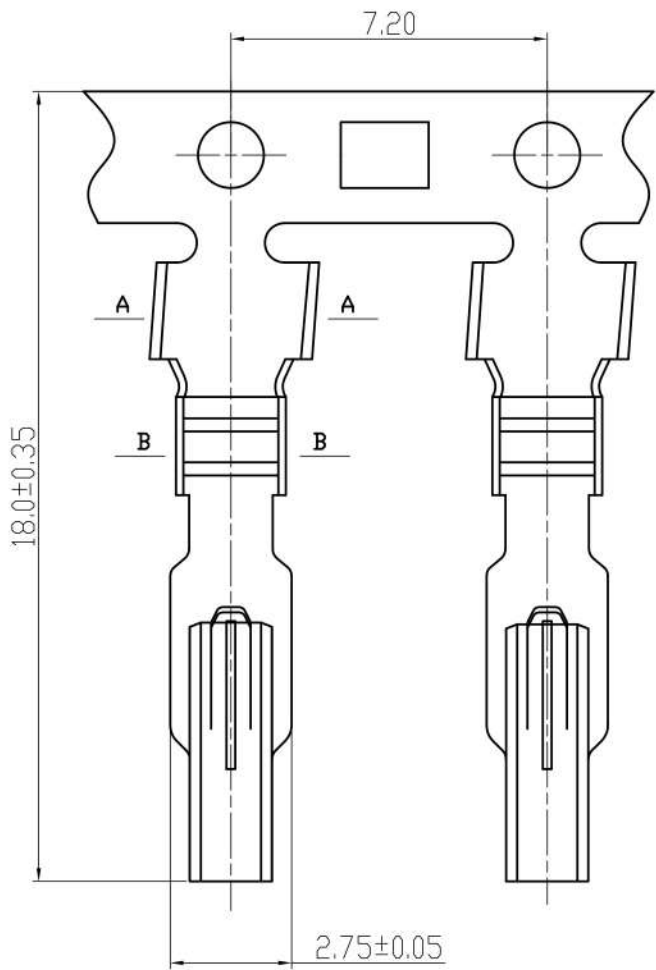

技术要求Specification:

- 1、材质：磷青铜，表面镀锡 Material:Phos.Bronze Tin-Plated
- 2、零件外观不得有有害毛刺、尖角、锐边和机械损伤;表面镀层应均匀、光亮、无雾斑、剥层等缺陷;

Parts may not have the appearance of harmful burrs,sharp corners,sharp edges and mechanical damage,surface coating should be uniform, bright,no fog spots,delamination and other defects.

TOLERANCE UNLESS OTHERWISE SPECIFIED		*: Inspection Item		Canner® www.canner.co.in			
.X±0.30	X.° ±1°	NO.	:Cp/Cpk and SPC Control Item	名称	3.96/5.08端子通用		
.XX±0.20	.X° ±			料号	SH39601-T	单位	mm
.XXX±0.10	.XX° ±			料厚	SH50801-T	版本	A/1
制图	赵旭强	料宽		比例	1:1		
审核	江树钦	日期	2022.08.19	角法	PROJ.		
批准	谭猛			规格书			

标记 MARK	更改内容 MODIFICATION	日期 DATE	修改 DRAW	核准 APPROVE

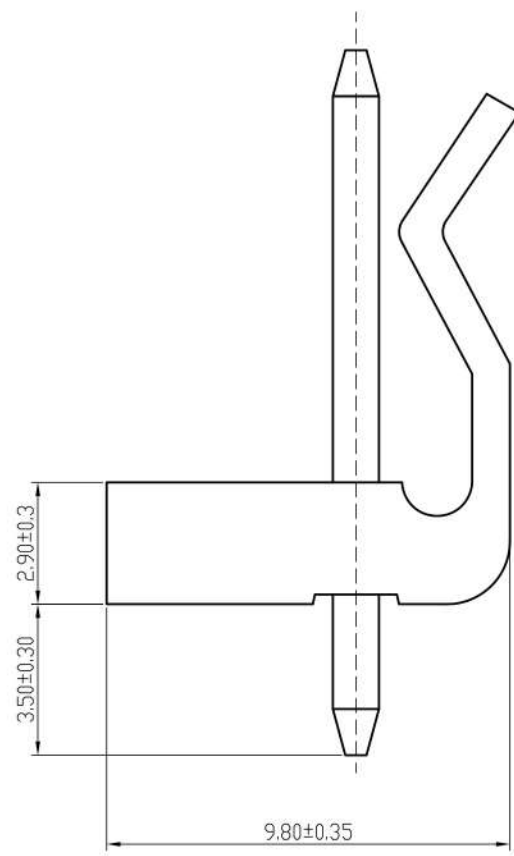
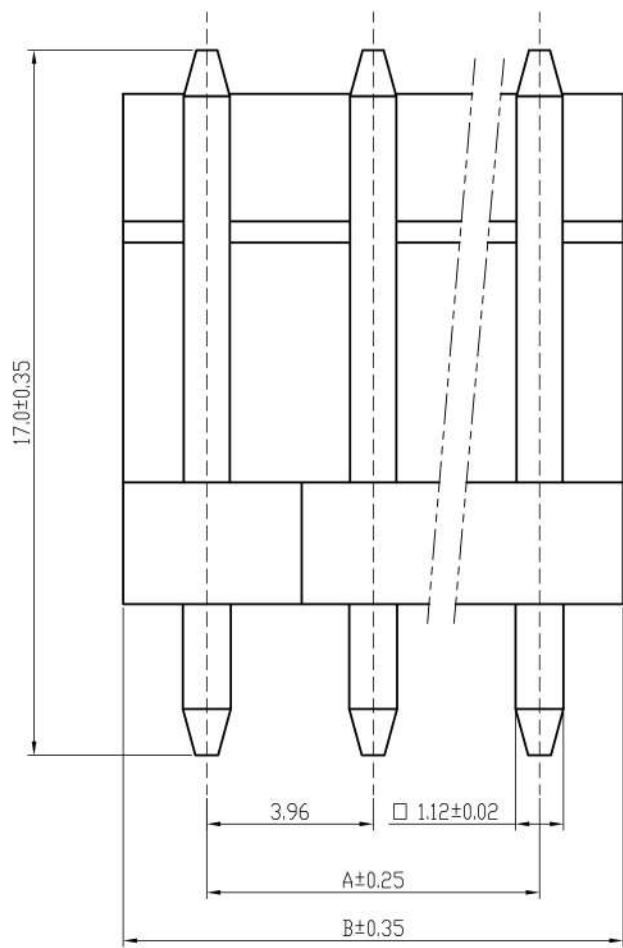

线数	料号	尺寸	
		A	B
2	SH39601-2A	3.96	7.92
3	SH39601-3A	7.92	11.88
4	SH39601-4A	11.88	15.84
5	SH39601-5A	15.84	19.80
6	SH39601-6A	19.80	23.76
7	SH39601-7A	23.76	27.72
8	SH39601-8A	27.72	31.68
9	SH39601-9A	31.68	35.64
10	SH39601-10A	35.64	39.60
11	SH39601-11A	39.60	43.56
12	SH39601-12A	43.56	47.52
13	SH39601-13A	47.52	51.48
14	SH39601-14A	51.48	55.44
15	SH39601-15A	55.44	59.40
16	SH39601-16A	59.40	63.36

技术要求Specification:

- 1、材质Material: 塑座 Base:PA66 UL94V-2;
针 Pin:黄铜 Brass Tin-Plated
- 2、塑件表面平整、光洁、无毛刺、气泡、变形、浇口无拉伤、缺料等不良现象。
Housing Surface Levelling、Clen and tidy、No burr、Air bubble、Deformation、No pull、Lackmaterial Unhealthy tendencies.

TOLERANCE UNLESS OTHERWISE SPECIFIED		*: Inspection Item		Canner® www.canner.co.in	
.X±0.30	ANGLES	NO.	:Cp/Cpk and SPC Control Item	名称	TJC6-NA
.XX±0.20	.X° ±0.0°			料号	SH39601-NA
.XXX±0.10	.X° ±0.00°	材料	PA66	比例	1:1
制图	丁浩然	料厚		版本	A/1
审核	林云昆	料宽		角法	规格书
批准	谭猛	日期	2024.08.07	PROJ.	

标记 MARK	更改内容 MODIFICATION	日期 DATE	修改 DRAW	核准 APPROVE

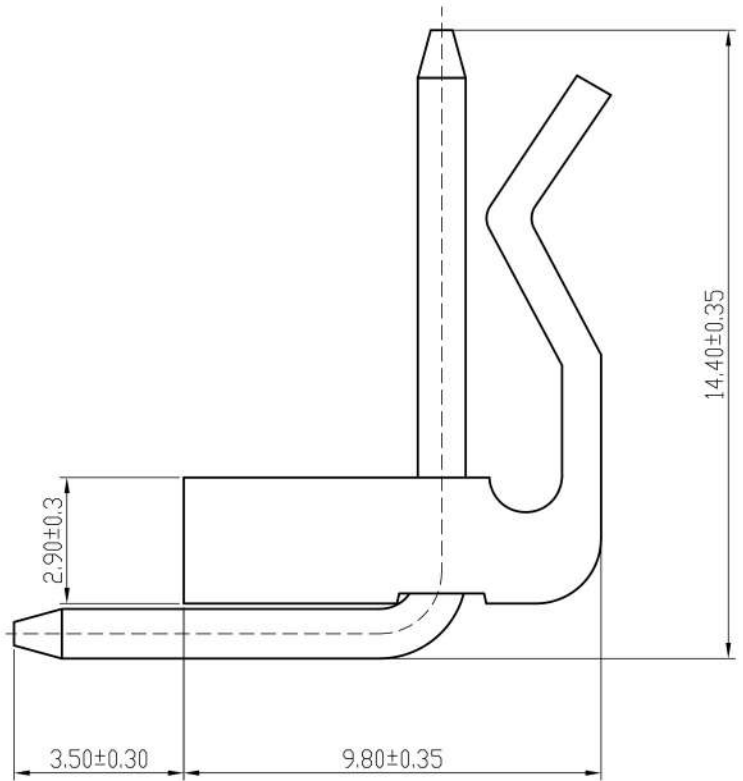
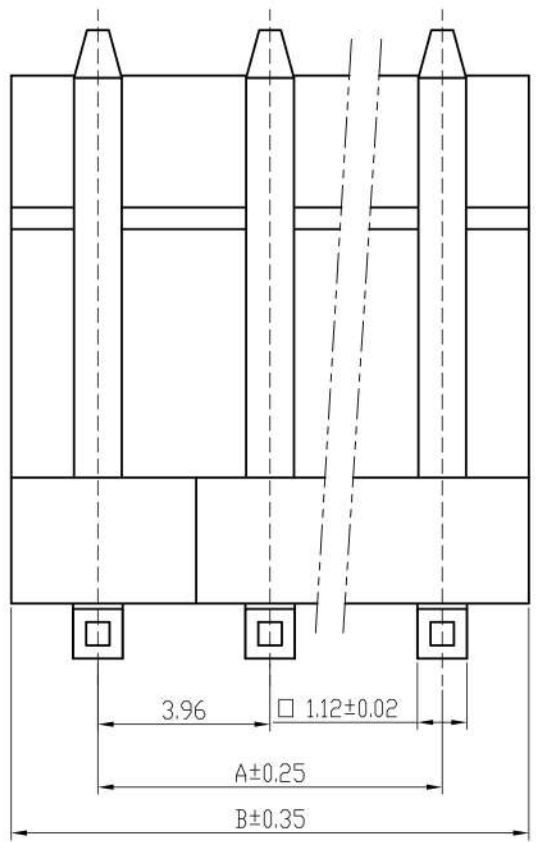

线数	料号	尺寸	
		A	B
2	SH39601-2AW	3.96	7.92
3	SH39601-3AW	7.92	11.88
4	SH39601-4AW	11.88	15.84
5	SH39601-5AW	15.84	19.80
6	SH39601-6AW	19.80	23.76
7	SH39601-7AW	23.76	27.72
8	SH39601-8AW	27.72	31.68
9	SH39601-9AW	31.68	35.64
10	SH39601-10AW	35.64	39.60
11	SH39601-11AW	39.60	43.56
12	SH39601-12AW	43.56	47.52
13	SH39601-13AW	47.52	51.48
14	SH39601-14AW	51.48	55.44
15	SH39601-15AW	55.44	59.40
16	SH39601-16AW	59.40	63.36

技术要求Specification:

- 1、材质Material: 塑座 Base:PA66 UL94V-2;
针 Pin:黄铜 Brass Tin-Plated
- 2、塑件表面平整、光洁、无毛刺、气泡、变形、浇口无拉伤、缺料等不良现象。
Housing Surface Levelling、Clen and tidy、No burr、Air bubble、Deformation、
No pull、Lackmaterial Unhealthy tendencies.

TOLERANCE UNLESS OTHERWISE SPECIFIED		*: Inspection Item		Canner® www.canner.co.in	
.X±0.30	ANGLES	NO.	:Cp/Cpk and SPC Control Item	名称	TJC6-NAW
.XX±0.20	.X° ±0.0°			料号	SH39601-NAW
.XXX±0.10	.X° ±0.00°	材料	PA66	料号	SH39601-NAW
制图	丁浩然	料厚		比例	1:1
审核	林云昆	料宽		版本	A/1
批准	谭猛	日期	2024.08.07	角法	规格书