

标记 MARK.	更改内容 MODIFICATION	日期 DATE	修改 DRAW	核准 APPROVE

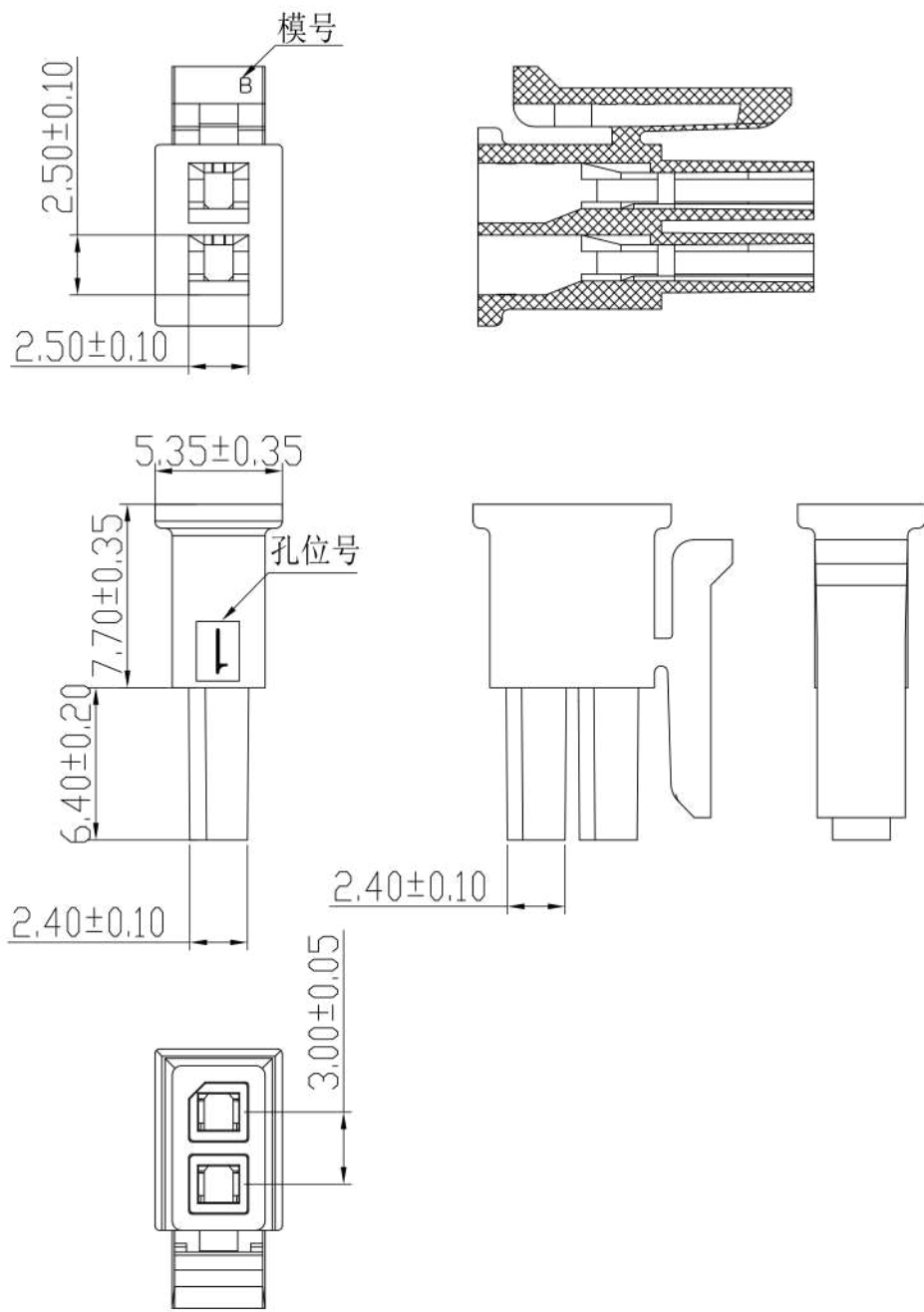

技术要求Specification:

- 1、材质Material: PA66 UL94V-0;
- 2、额定电流 Current rating:5.0A AC,DC
- 3、额定电压 Voltage rating: 250V AC,DC
- 4、温度范围 Temperature range:-25℃to+85℃
- 5、接触电阻 Contact resistance:≤20mΩ
- 6、绝缘电阻 Insulation resistance:≥1000MΩ
- 7、耐压 Withstand voltage:1000V AC/minute
- 8、塑件表面平整光洁, 无明显的毛刺、气泡、变形、浇口拉伤、缺料等不良现象。  
Plastic surface smooth and clean, no obvious burrs, bubbles, distortion, gate strain, lack of material and other undesirable phenomena.

TOLERANCE UNLESS OTHERWISE SPECIFIED		*: Inspection Item		Canner www.canner.co.in		
.X±0.30	X.° ±1°	(NO.)	:Cp/Cpk and SPC Control Item		名称 小5557/43025 HOUSING	
.XX±0.20	.X° ±		材料 PA66	料厚 THICK	编号 SH30000-2*1P	单位 mm
.XXX±0.10	.XX° ±	料宽 WIDE	比例 1:1	版本 R E V.	A	
制图 DRAWIN	赵旭强	日期 DATE	2023. 09. 20	角法 PROJ.	规格书	
审核 CHECKED	林云昆					
批准 APPROVE	谭猛					

标记 MARK	更改内容 MODIFICATION	日期 DATE	修改 DRAW	核准 APPROVE

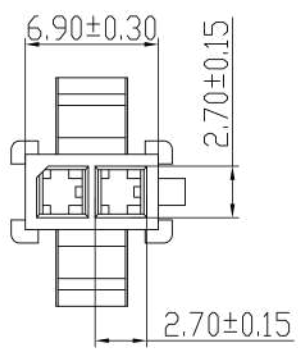
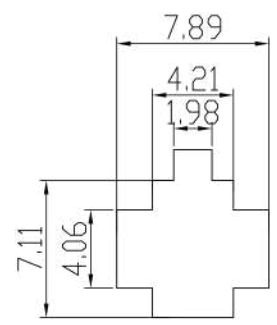
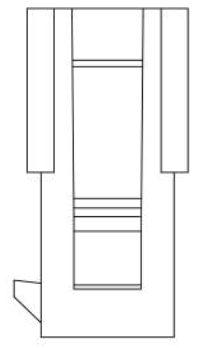
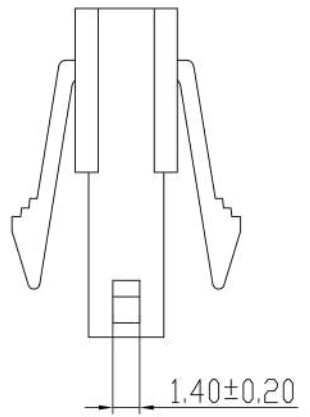
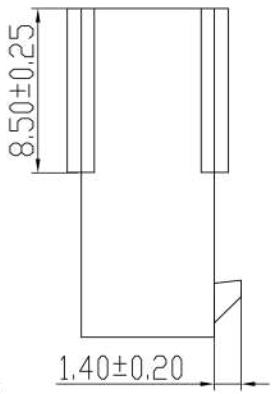
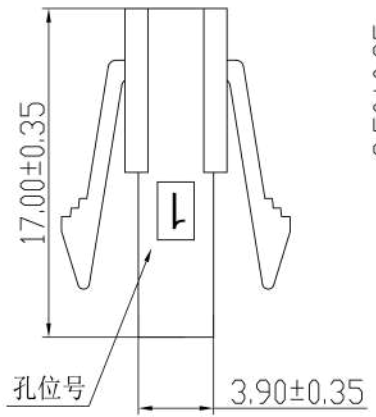
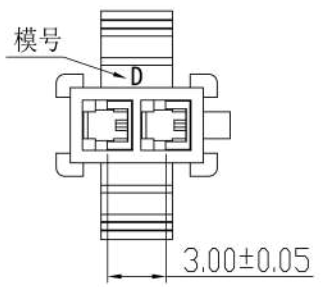

适应基板厚度: 1.6mm  
安装参考尺寸

技术要求Specification:  
 1、材质Material: PA66 UL94V-0;  
 2、额定电流 Current rating:5.0A AC,DC  
 3、额定电压 Voltage rating: 250V AC,DC  
 4、温度范围 Temperature range:-25℃to+85℃  
 5、接触电阻 Contact resistance:≤20mΩ  
 6、绝缘电阻 Insulation resistance:≥1000MΩ  
 7、耐压 Withstand voltage:1000V AC/minute  
 8、塑件表面平整光洁,无明显的毛刺、气泡、变形、浇口拉伤、缺料等不良现象。  
 Plastic surface smooth and clean, no obvious burrs, bubbles, distortion, gate strain, lack of material and other undesirable phenomena.

TOLERANCE UNLESS OTHERWISE SPECIFIED		*: Inspection Item		Canner® www.canner.co.in		
.X±0.30	X.° ±1°	(NO)	:Cp/Cpk and SPC Control Item		名称 小5559/43020 HOUSING	
.XX±0.20	.X° ±		材料 PA66	编号 SH30000-2*1R	单位 mm	
.XXX±0.10	.XX° ±	料厚 THICK	比例 1:1	版本 R E V.	规格书	
		料宽 WIDE		日期 2023.09.26	角法 PROJ.	
制图 DRAWIN	赵旭强	日期 DATE	2023.09.26	角法 PROJ.		
审核 CHECKED	林云昆					
批准 APPROVE	谭猛					

标记 MARK.	更改内容 MODIFICATION	日期 DATE	修改 DRAW	核准 APPROVE

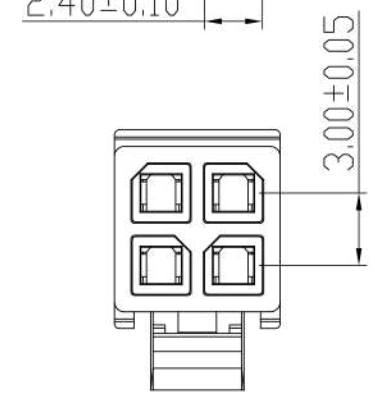
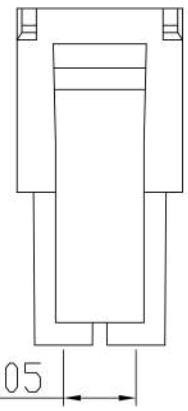
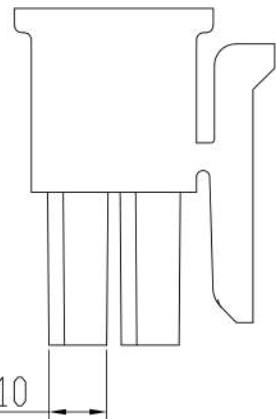
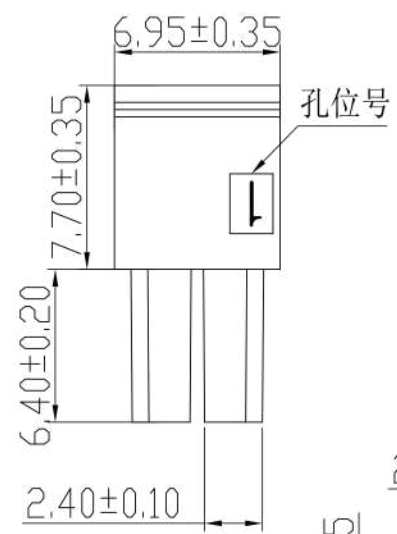
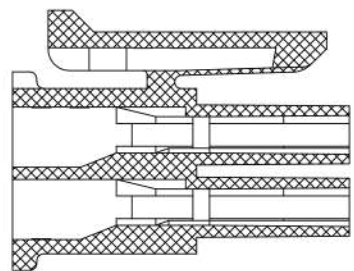
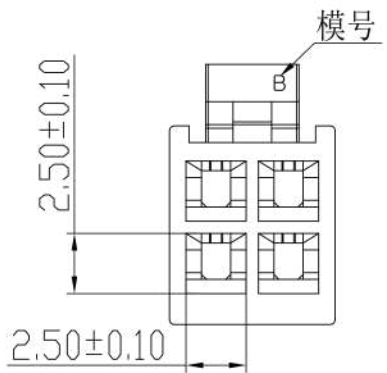

2.40±0.10

3.00±0.05

技术要求Specification:  
 1、材质Material: PA66 UL94V-0;  
 2、额定电流 Current rating:5.0A AC,DC  
 3、额定电压 Voltage rating: 250V AC,DC  
 4、温度范围 Temperature range:-25℃to+85℃  
 5、接触电阻 Contact resistance:≤20mΩ  
 6、绝缘电阻 Insulation resistance:≥1000MΩ  
 7、耐压 Withstand voltage:1000V AC/minute  
 8、塑件表面平整光洁,无明显的毛刺、气泡、变形、浇口拉伤、缺料等不良现象。  
 Plastic surface smooth and clean, no obvious burrs, bubbles, distortion, gate strain, lack of material and other undesirable phenomena.

TOLERANCE UNLESS OTHERWISE SPECIFIED		*: Inspection Item		Canner® www.canner.co.in			
.X±0.30	X.° ±1°	NO.	:Cp/Cpk and SPC Control Item	名称	小5557/43025 HOUSING		
.XX±0.20	.X° ±			材料	PA66	编号	SH30000-2*2P
.XXX±0.10	.XX° ±	料厚		比例	1:1	单位	mm
制图	赵旭强	料宽		角法		版本	A
审核	林云昆	日期	2023.09.20	角法	PROJ.	规格书	
批准	谭猛	日期	2023.09.20	角法	PROJ.	规格书	

标记 MARK.	更改内容 MODIFICATION	日期 DATE	修改 DRAW	核准 APPROVE

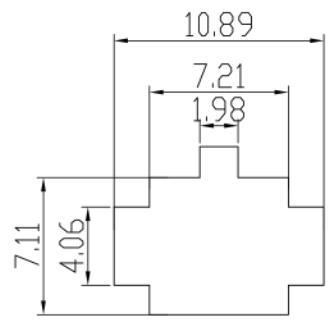
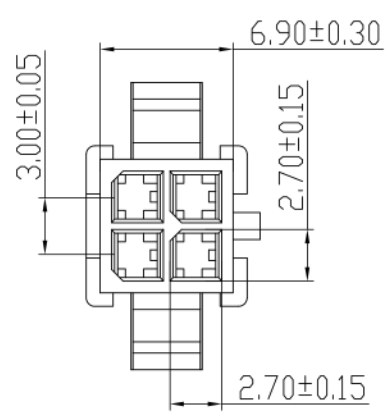
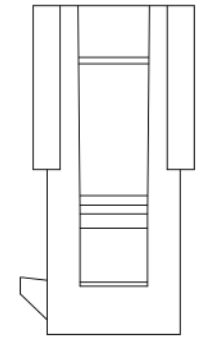
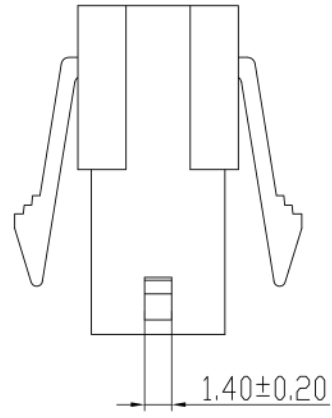
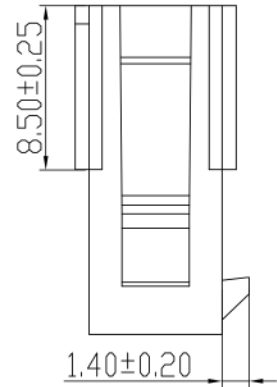
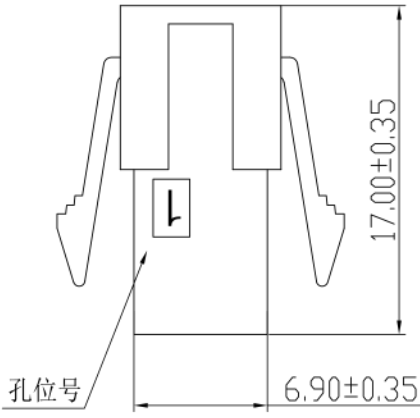
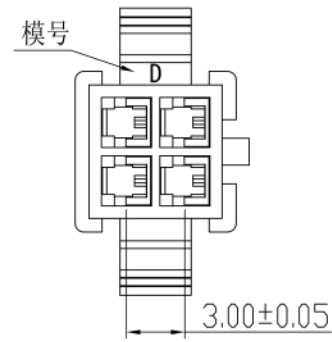

适应基板厚度: 1.6mm  
安装参考尺寸

技术要求Specification:  
 1、材质Material: PA66 UL94V-0;  
 2、额定电流 Current rating:5.0A AC,DC  
 3、额定电压 Voltage rating: 250V AC,DC  
 4、温度范围 Temperature range:-25℃to+85℃  
 5、接触电阻 Contact resistance:≤20mΩ  
 6、绝缘电阻 Insulation resistance:≥1000MΩ  
 7、耐压 Withstand voltage:1000V AC/minute  
 8、塑件表面平整光洁,无明显的毛刺、气泡、变形、浇口拉伤、缺料等不良现象。  
 Plastic surface smooth and clean, no obvious burrs, bubbles, distortion, gate strain, lack of material and other undesirable phenomena.

TOLERANCE UNLESS OTHERWISE SPECIFIED		*: Inspection Item		Canner www.canner.co.in			
.X±0.30	X.° ±1°	(NO.)	:Cp/Cpk and SPC Control Item	名称	小5559/43020 HOUSING		
.XX±0.20	.X° ±			材料	PA66	编号	SH30000-2*2R
.XXX±0.10	.XX° ±	料厚	THICK	比例	1:1	单位	mm
制图	赵旭强	料宽	WIDE	角法	1:1	版本	A
审核	林云昆	日期	2023.09.26	角法	PROJ.	规格书	
批准	谭猛	日期	2023.09.26	角法	PROJ.	规格书	

标记 MARK.	更改内容 MODIFICATION	日期 DATE	修改 DRAW	核准 APPROVE

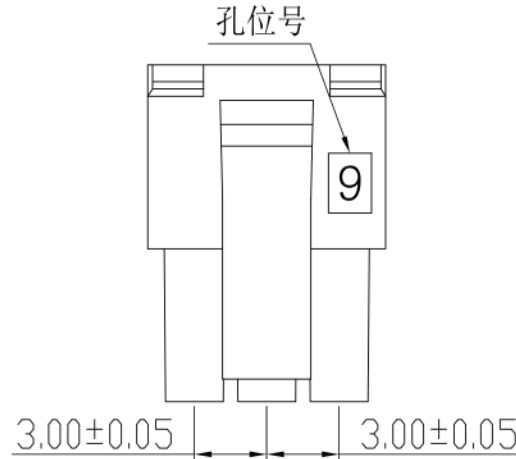
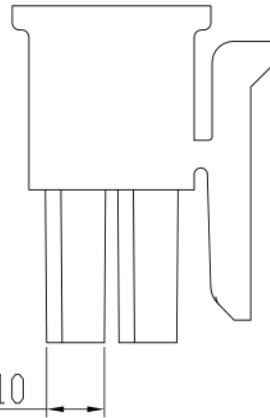
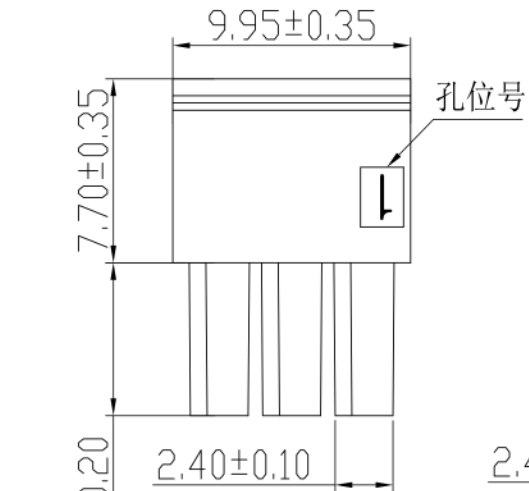
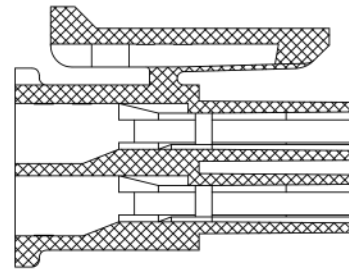
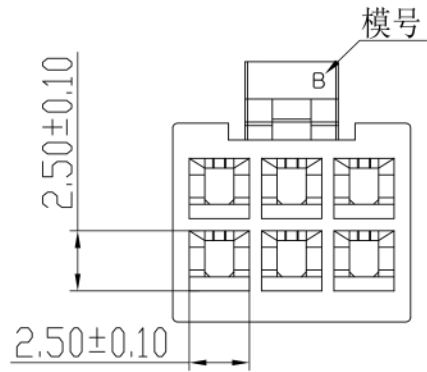

技术要求Specification:

- 1、材质Material: PA66 UL94V-0;
- 2、额定电流 Current rating:5.0A AC,DC
- 3、额定电压 Voltage rating: 250V AC,DC
- 4、温度范围 Temperature range:-25℃to+85℃
- 5、接触电阻 Contact resistance:≤20mΩ
- 6、绝缘电阻 Insulation resistance:≥1000MΩ
- 7、耐压 Withstand voltage:1000V AC/minute
- 8、塑件表面平整光洁, 无明显的毛刺、气泡、变形、浇口拉伤、缺料等不良现象。

Plastic surface smooth and clean, no obvious burrs, bubbles, distortion, gate strain, lack of material and other undesirable phenomena.

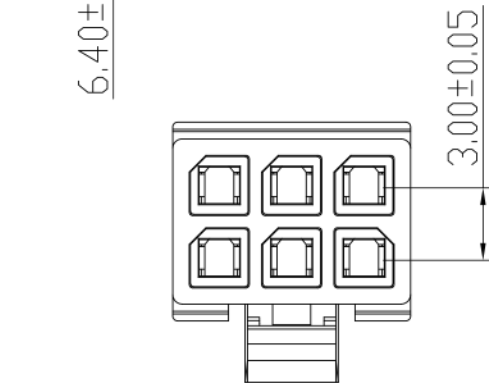

TOLERANCE UNLESS OTHERWISE SPECIFIED		*: Inspection Item		www.canner.co.in			
.X±0.30	X.° ±1°	NO.	:Cp/Cpk and SPC Control Item	名称	小5557/43025 HOUSING		
.XX±0.20	.X° ±			材料	PA66	编号	SH30000-2*3P
.XXX±0.10	.XX° ±	料厚		比例	1:1	单位	mm
制图	赵旭强	料宽		角法		版本	A
审核	林云昆	日期	2023.09.20	角法		规格书	
批准	谭猛	日期	2023.09.20	角法			

标记 MARK.	更改内容 MODIFICATION	日期 DATE	修改 DRAW	核准 APPROVE

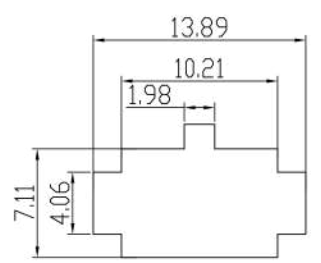
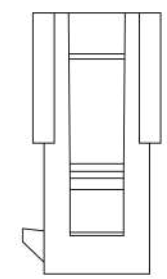
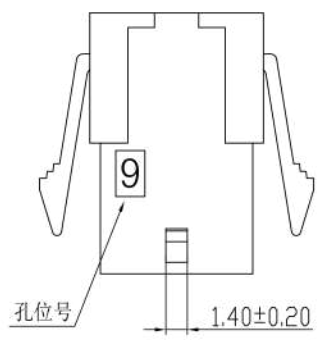
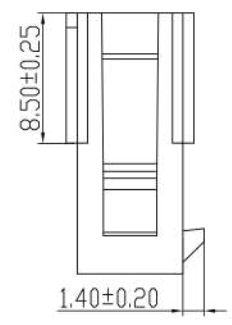
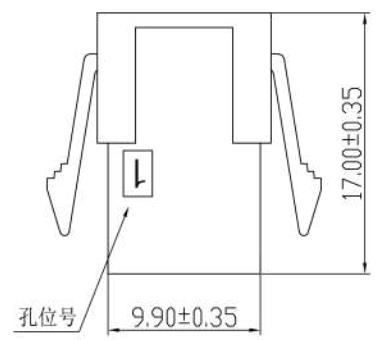
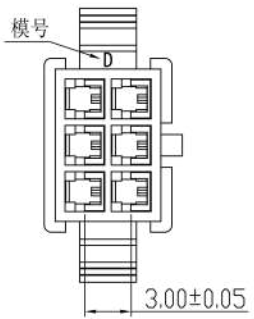

适应基板厚度: 1.6mm  
安装参考尺寸

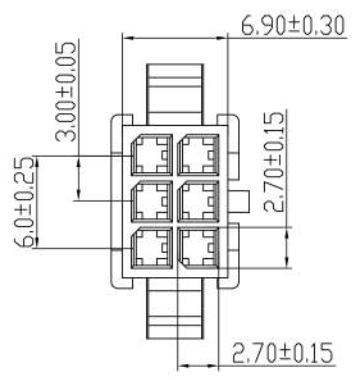

技术要求Specification:

- 1、材质Material: PA66 UL94V-0;
- 2、额定电流 Current rating:5.0A AC,DC
- 3、额定电压 Voltage rating: 250V AC,DC
- 4、温度范围 Temperature range:-25℃to+85℃
- 5、接触电阻 Contact resistance:≤20mΩ
- 6、绝缘电阻 Insulation resistance:≥1000MΩ
- 7、耐压 Withstand voltage:1000V AC/minute
- 8、塑件表面平整光洁, 无明显的毛刺、气泡、变形、浇口拉伤、缺料等不良现象。

Plastic surface smooth and clean, no obvious burrs, bubbles, distortion, gate strain, lack of material and other undesirable phenomena.

TOLERANCE UNLESS OTHERWISE SPECIFIED		*: Inspection Item		Canner® www.canner.co.in	
.X±0.30	X.° ±1°	(NO.)	:Cp/Cpk and SPC Control Item	名称	小5559/43020 HOUSING
.XX±0.20	.X° ±			材料	PA66
.XXX±0.10	.XX° ±	料厚		比例	1:1
		料宽		角法	角法
制图	赵旭强	日期	2023.09.26	角法	角法
审核	林云昆	日期	2023.09.26	角法	角法
批准	谭猛	日期	2023.09.26	角法	角法
					规格书

标记 MARK.	更改内容 MODIFICATION	日期 DATE	修改 DRAW	核准 APPROVE

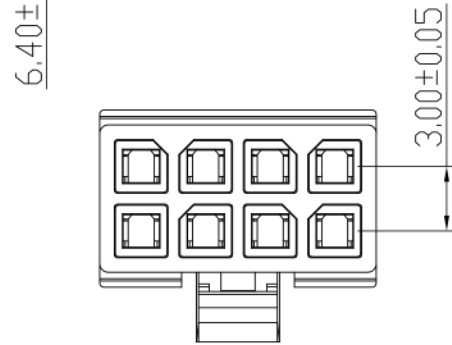
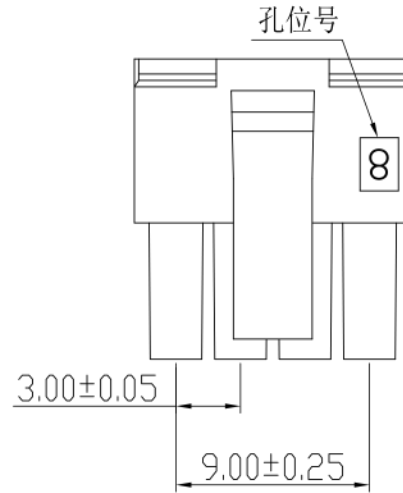
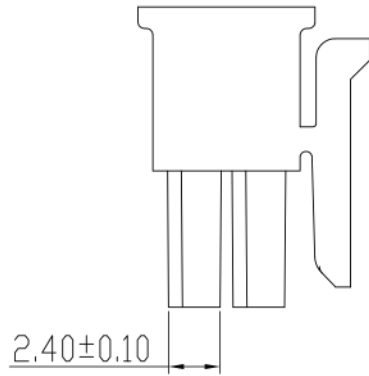
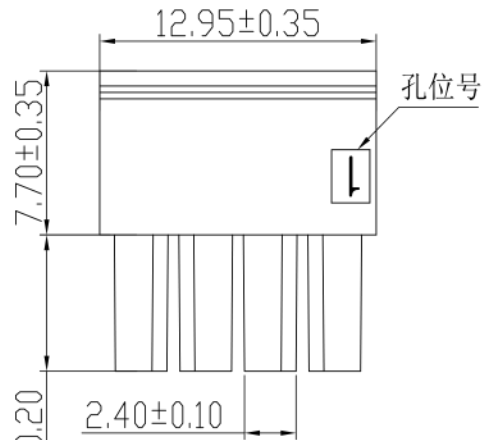
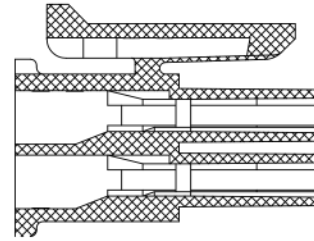
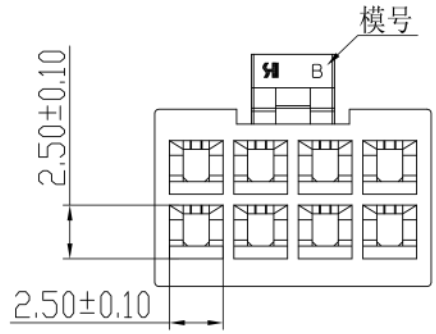

技术要求Specification:

- 1、材质Material: PA66 UL94V-0;
- 2、额定电流 Current rating:5.0A AC,DC
- 3、额定电压 Voltage rating: 250V AC,DC
- 4、温度范围 Temperature range:-25℃to+85℃
- 5、接触电阻 Contact resistance:≤20mΩ
- 6、绝缘电阻 Insulation resistance:≥1000MΩ
- 7、耐压 Withstand voltage:1000V AC/minute
- 8、塑件表面平整光洁, 无明显的毛刺、气泡、变形、浇口拉伤、缺料等不良现象。

Plastic surface smooth and clean, no obvious burrs, bubbles, distortion, gate strain, lack of material and other undesirable phenomena.

TOLERANCE UNLESS OTHERWISE SPECIFIED		*: Inspection Item		www.canner.co.in			
.X±0.30	X.° ±1°	(NO.)	:Cp/Cpk and SPC Control Item	名称	小5557/43025 HOUSING		
.XX±0.20	.X° ±			材料	PA66	编号	SH30000-2*4P
.XXX±0.10	.XX° ±	料厚		比例	1:1	单位	mm
制图	赵旭强	料宽		角法		版本	A
审核	林云昆	日期	2023.09.20	角法		批准	谭猛
批准	谭猛	日期	2023.09.20	角法		批准	谭猛

规格书

标记 MARK.	更改内容 MODIFICATION	日期 DATE	修改 DRAW	核准 APPROVE

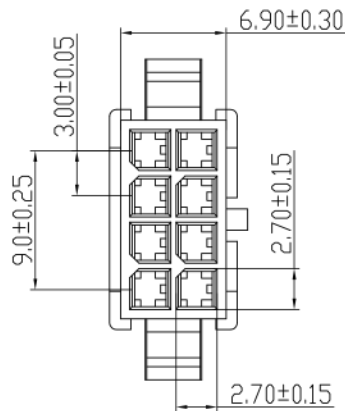
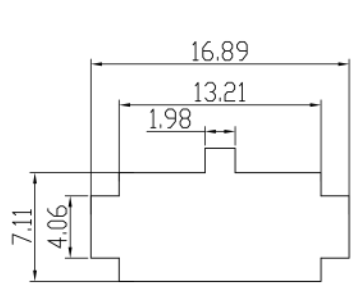
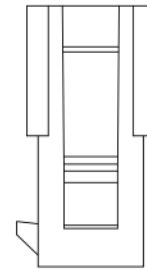
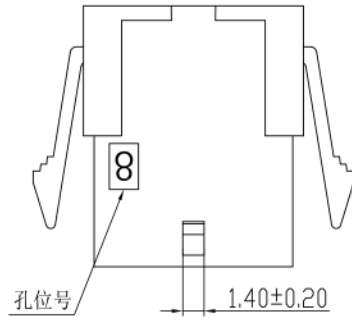
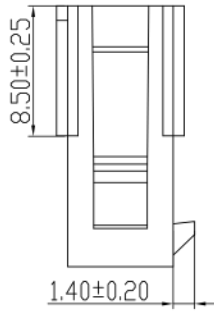
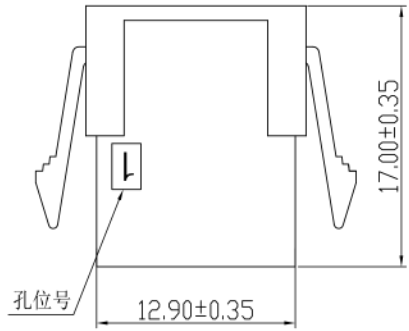
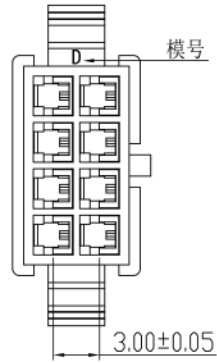

适应基板厚度: 1.6mm  
安装参考尺寸

技术要求Specification:

- 1、材质Material: PA66 UL94V-0;
- 2、额定电流 Current rating:5.0A AC,DC
- 3、额定电压 Voltage rating: 250V AC,DC
- 4、温度范围 Temperature range:-25℃to+85℃
- 5、接触电阻 Contact resistance:≤20mΩ
- 6、绝缘电阻 Insulation resistance:≥1000MΩ
- 7、耐压 Withstand voltage:1000V AC/minute
- 8、塑件表面平整光洁, 无明显的毛刺、气泡、变形、浇口拉伤、缺料等不良现象。

Plastic surface smooth and clean, no obvious burrs, bubbles, distortion, gate strain, lack of material and other undesirable phenomena.

TOLERANCE UNLESS OTHERWISE SPECIFIED		*: Inspection Item		Canner® www.canner.co.in		
.X±0.30	X.° ±1°	(NO.)	:Cp/Cpk and SPC Control Item		名称 小5559/43020 HOUSING	
.XX±0.20	.X° ±		材料 PA66	料厚 THICK	编号 SH30000-2*4R	单位 mm
.XXX±0.10	.XX° ±	料宽 WIDE	比例 SCALE	1:1	版本 R E V.	A
制图 DRAWIN	赵旭强	日期 DATE	2023.09.26	角法 PROJ.	规格书	
审核 CHECKED	林云昆					
批准 APPROVE	谭猛					



标记 MARK.	更改内容 MODIFICATION	日期 DATE	修改 DRAW	核准 APPROVE

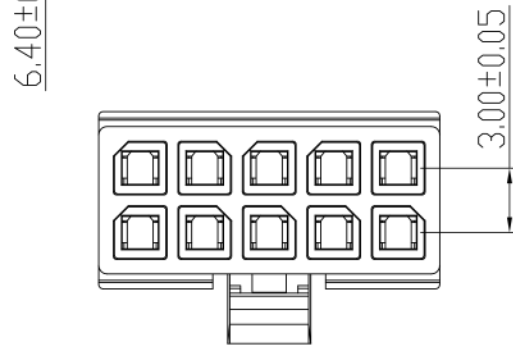
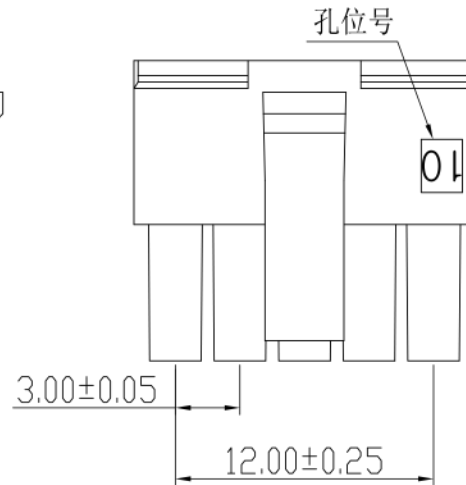
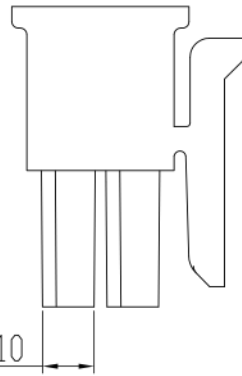
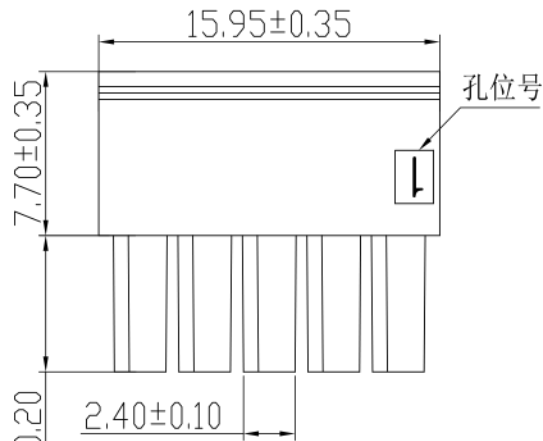
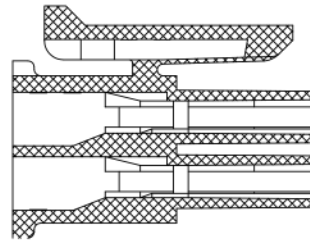
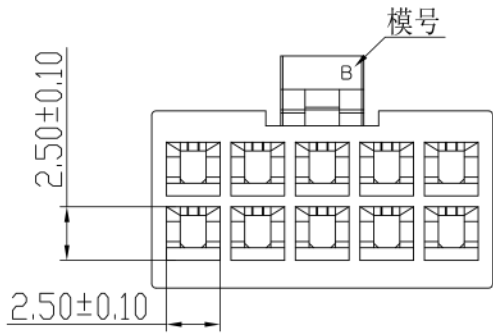

技术要求Specification:

- 1、材质Material: PA66 UL94V-0;
- 2、额定电流 Current rating:5.0A AC,DC
- 3、额定电压 Voltage rating: 250V AC,DC
- 4、温度范围 Temperature range:-25℃to+85℃
- 5、接触电阻 Contact resistance:≤20mΩ
- 6、绝缘电阻 Insulation resistance:≥1000MΩ
- 7、耐压 Withstand voltage:1000V AC/minute
- 8、塑件表面平整光洁,无明显的毛刺、气泡、变形、浇口拉伤、缺料等不良现象。

Plastic surface smooth and clean, no obvious burrs, bubbles, distortion, gate strain, lack of material and other undesirable phenomena.

TOLERANCE UNLESS OTHERWISE SPECIFIED		*: Inspection Item		Canner® www.canner.co.in			
.X±0.30	X.° ±1°	(NO.)	:Cp/Cpk and SPC Control Item	名称	小5557/43025 HOUSING		
.XX±0.20	.X° ±			材料	PA66	编号	SH30000-2*5P
.XXX±0.10	.XX° ±	料厚		比例	1:1	单位	mm
制图	赵旭强	料宽		角法		版本	A
审核	林云昆	日期	2023.09.20	角法		批准	谭猛
批准	谭猛	日期	2023.09.20	角法		批准	谭猛

规格书

标记 MARK.	更改内容 MODIFICATION	日期 DATE	修改 DRAW	核准 APPROVE

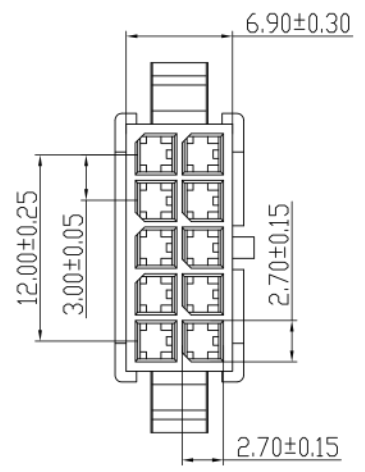
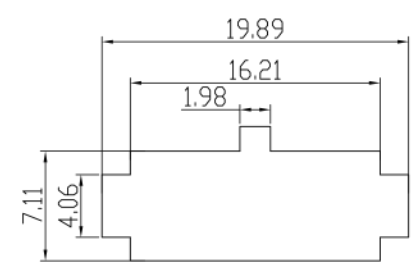
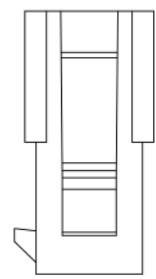
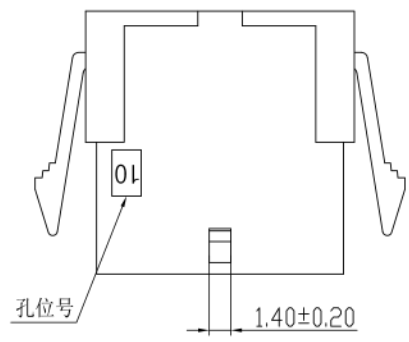
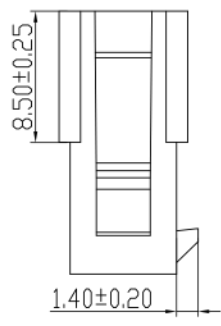
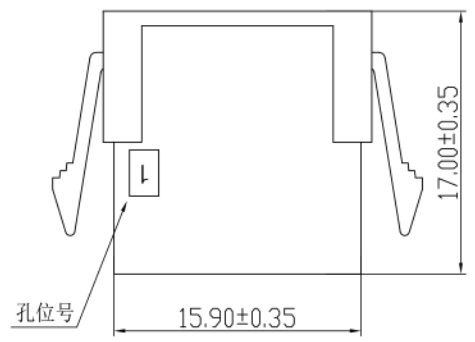
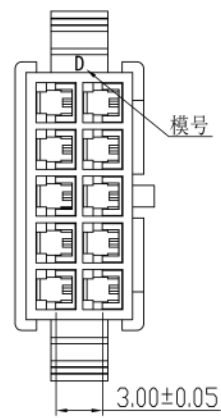

适应基板厚度: 1.6mm  
安装参考尺寸

技术要求Specification:

- 1、材质Material: PA66 UL94V-0;
- 2、额定电流 Current rating:5.0A AC,DC
- 3、额定电压 Voltage rating: 250V AC,DC
- 4、温度范围 Temperature range:-25℃to+85℃
- 5、接触电阻 Contact resistance:≤20mΩ
- 6、绝缘电阻 Insulation resistance:≥1000MΩ
- 7、耐压 Withstand voltage:1000V AC/minute
- 8、塑件表面平整光洁, 无明显的毛刺、气泡、变形、浇口拉伤、缺料等不良现象。

Plastic surface smooth and clean, no obvious burrs, bubbles, distortion, gate strain, lack of material and other undesirable phenomena.

TOLERANCE UNLESS OTHERWISE SPECIFIED		*: Inspection Item		Canner® www.canner.co.in		
.X±0.30	X.° ±1°	(NO.)	:Cp/Cpk and SPC Control Item		名称 TITLE	
.XX±0.20	.X° ±		材料 MATERIAL	PA66	小5559/43020 HOUSING	
.XXX±0.10	.XX° ±	料厚 THICK	/		编号 DWG NO.	单位 UNIT
		料宽 WIDE			比例 SCALE	SH30000-2*5R
制图 DRAWIN	赵旭强	日期 DATE	2023.09.26	角法 PROJ.	版本 R E V.	A
审核 CHECKED	林云昆	批准 APPROVE		谭猛	规格书	

标记 MARK	更改内容 MODIFICATION	日期 DATE	修改 DRAW	核准 APPROVE

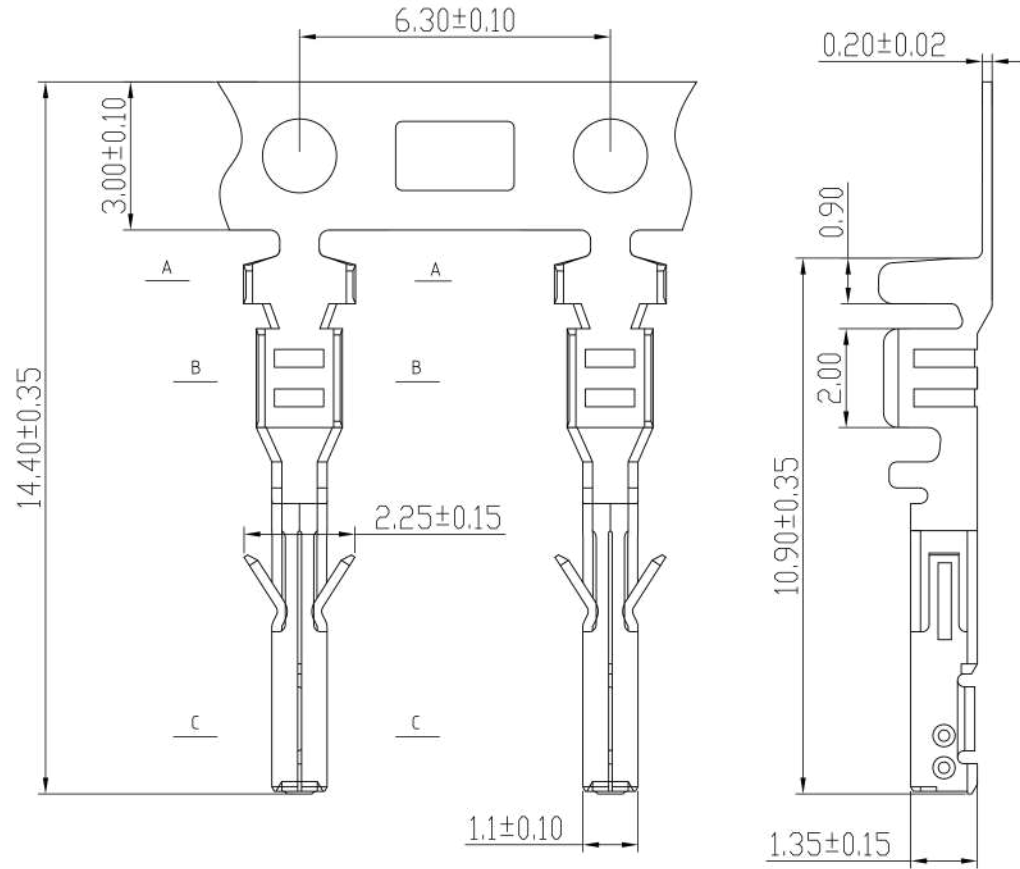

技术要求Specification:

1、材质：磷青铜,表面镀锡;

Material:Phos.Bronze Tin-Plated

2、零件外观不得有有害毛刺、尖角、锐边和机械损伤;表面镀层应均匀、光亮、无雾斑、剥层等缺陷;

Parts may not have the appearance of harmful burrs,sharp corners,sharp edges and mechanical damage,surface coating should be uniform, bright,no fog spots,delamination and other defects.

4、适用导线范围：Applicable wire:AWG # 20-# 24 ;

5、适配塑件型号：SH30000-NP;

Suitable Housing Type: SH30000-NP;

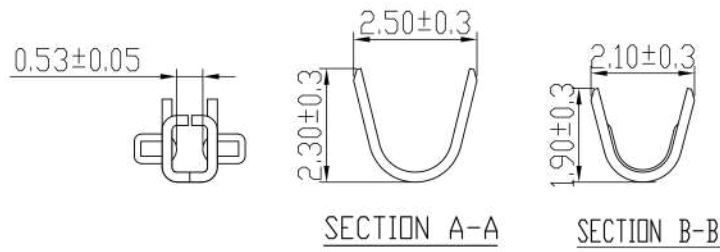

TOLERANCE UNLESS OTHERWISE SPECIFIED		*: Inspection Item		Canner® www.canner.co.in			
.X±0.30	X.° ±1°	(NO.)	:Cp/Cpk and SPC Control Item	名称	小5556/43030 TERMINAL		
.XX±0.20	.X° ±			材料	磷青铜	编号	SH30000-PT-02
.XXX±0.10	.XX° ±	料厚	0.20 mm	比例	1:1	单位	mm
制图	赵旭强	料宽		角法		版本	A
审核	江树钦	日期	2023.09.20	角法	☉	规格书	
批准	谭猛	日期	2023.09.20	角法	☉	规格书	

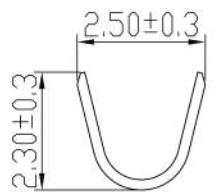
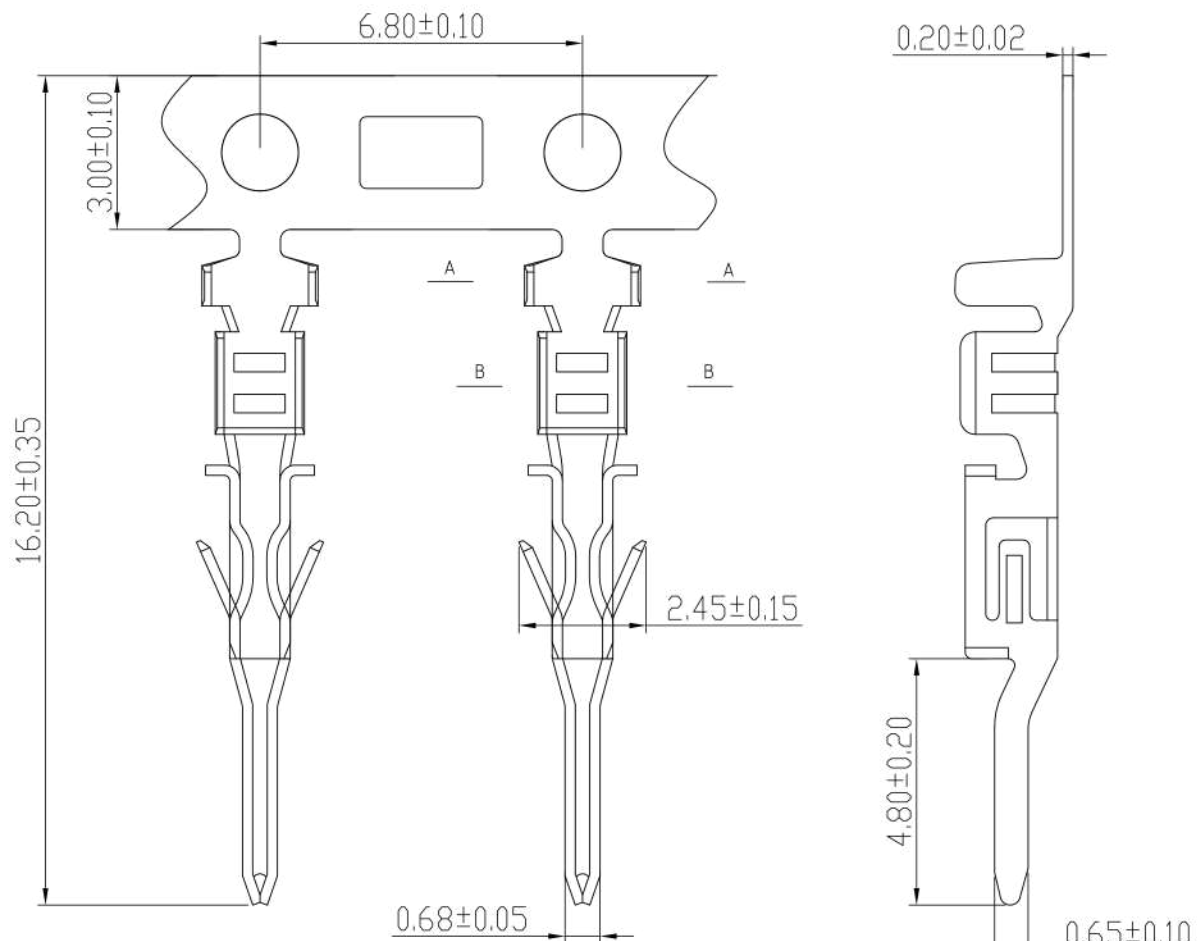

SECTION A-A

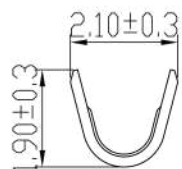

SECTION B-B

标记 MARK	更改内容 MODIFICATION	日期 DATE	修改 DRAW	核准 APPROVE

技术要求 Specification:

1、材质：磷青铜，表面镀锡；

Material: Phos. Bronze Tin-Plated

2、零件外观不得有有害毛刺、尖角、锐边和机械损伤；表面镀层应均匀、光亮、无雾斑、剥层等缺陷；

Parts may not have the appearance of harmful burrs, sharp corners, sharp edges and mechanical damage, surface coating should be uniform, bright, no fog spots, delamination and other defects.

4、适用导线范围：Applicable wire: AWG # 20-# 24；

5、适配塑件型号：SH30000-NR；

Suitable Housing Type: SH30000-NR；

TOLERANCE UNLESS OTHERWISE SPECIFIED		*: Inspection Item		Canner® www.canner.co.in			
.X±0.30	X.° ±1°	(NO.)	:Cp/Cpk and SPC Control Item	名称	小5558/43031 TERMINAL		
.XX±0.20	.X° ±			材料	磷青铜	编号	SH30000-RT-02
.XXX±0.10	.XX° ±	料厚	0.20 mm	比例	1:1	单位	mm
制图	赵旭强	料宽		角法		版本	A
审核	江树钦	日期	2023.09.20	角法	PROJ.	规格书	
批准	谭猛	日期	2023.09.20	角法	PROJ.	规格书	